

AMERICAS
REGION



Tate.®

IMPERIAL DATA SHEET INFORMATION

Tate Grid+ LEC

Aluminum Structural Ceiling
Grid System for Data Centers

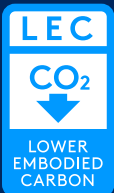

tateglobal.com

**BUILDING A
SMARTER WORLD
TOGETHER.**

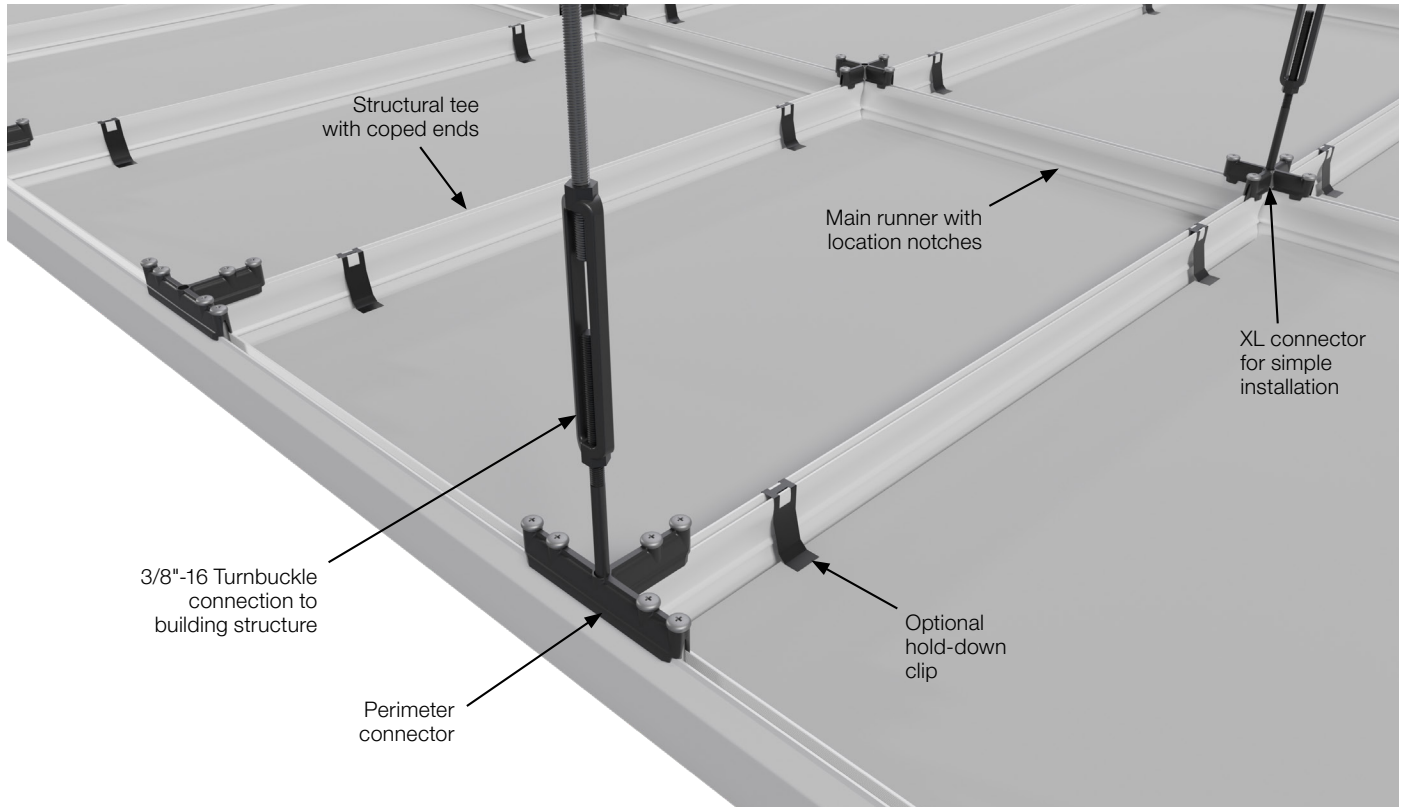

Grid Specifications

- Pre-engineered aluminum structural ceiling grid with continuously threaded 3/8"-16 bottom slot
- Grid consists of main runners with notches for precise location and connection of coped structural tees using four screws
- Capable of supporting power modules, light fixtures, cable trays, partitions, and other accessories
- Load performance based on building connection spacing of 4 ft. on center
 - Max grid point load at midspan of 475 lbs.
 - Max grid uniform load of 75 lbs/ft²
 - Safety factor 2x

- System weight on 4'x4' suspension grid:
 - 2'x4' Grid: 0.71 lb/ft²*
 - 2'x2' Grid: 0.93 lb/ft²**
- Grid member center-to-center spacing can be selected to accommodate various modules (see page 4 for more information)
- All bolt connections to the top slot or bottom slot of the grid should be tightened flush to a washer with a torque value between 20 in-lbs and 30 in-lbs

* System weights include (2'x4'):
 - Grid+ LEC main runners
 - Grid+ LEC tees
 - (4) 7" Turnbuckles
 - (4) 4 Hole Cross Connectors
 - (4) 8 Hole Cross Connectors
 - (48) 5/16"-18 x 9/16" Screw w/ Lockwasher

** System weights include (2'x2'):
 - Grid+ LEC main runners
 - Grid+ LEC tees
 - (4) 7" Turnbuckles
 - (12) 4 Hole Cross Connectors
 - (4) 8 Hole Cross Connectors
 - (80) 5/16"-18 x 9/16" Screw w/ Lockwasher

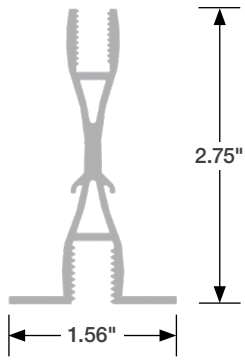

Mains, tees, and floating perimeter

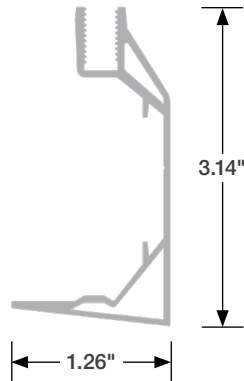

Fixed perimeter extrusion (optional)

Connector Specifications

- High-strength cast steel
- Corrosion resistant
- Ribs on connector engage with grid and prevent racking
- Attaches to grid members with 5/16"-18 screws
- 3/8" -16 turnbuckles with starter rod threads into connectors on a nominal 4'x4' spacing
- All connectors are painted black

Components

- 144" main runner / 144" perimeter angle
- 24" structural tee / 48" structural tee (nominal)
- Field connector / XL connector
- Perimeter connector
- Corner connector
- 5/16"-18 x 1-9/16" screws w/ 5/16" lock washer
- 3/8"-16 x 7" turnbuckle assembly with starter rod
- Optional components
 - Ceiling hold-down clips
 - Factory-applied gasket
- Components supplied by others
 - Ceiling tile
 - Threaded rod and connection to building



Quick and easy main and cross tee connections

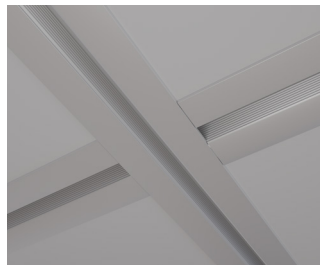

Threaded 3/8" slot for easy attachment of equipment



Field connector PN47690



Corner connector PN47279



Perimeter connector PN47728



XL connector - 8 Hole PN47691

Grid Options

- Grid color: White Black (other)
- Standard grid spacing options (see page 3 for detail)
- 24" / 24" 24" / 48"
- 24-1/2" / 24-1/2" 24-1/2" / 48-1/2"
- Custom grid spacing options available



Hold-down clip (optional)
PN49580 • PN49581

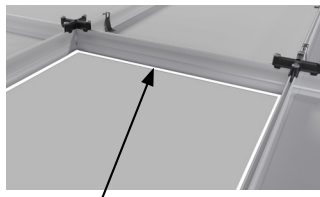

Factory-applied gasket (optional)

Profile Options

See page 8 for details

Field and Floating Perimeter

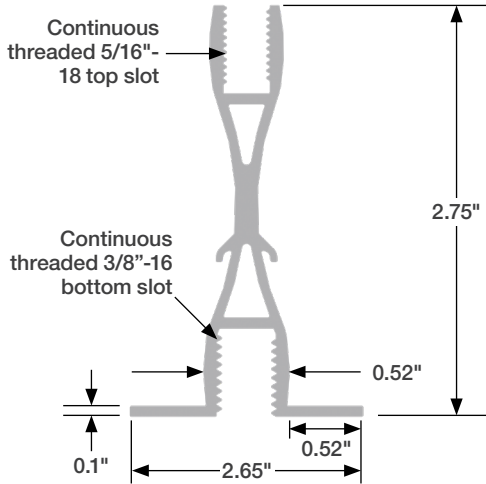

Fixed Perimeter

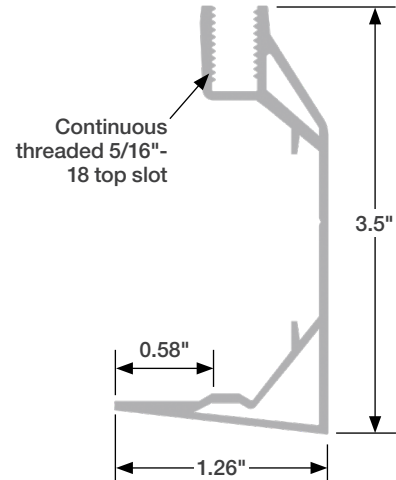

Performance Criteria

The bottom side of the structural grid is supplied with a 3/8"-16 continuous threaded slot for mounting items directly to the grid. Refer to the table below for load performance details on the grid and connections.

Structural Tee Deflection (Midspan Beam)

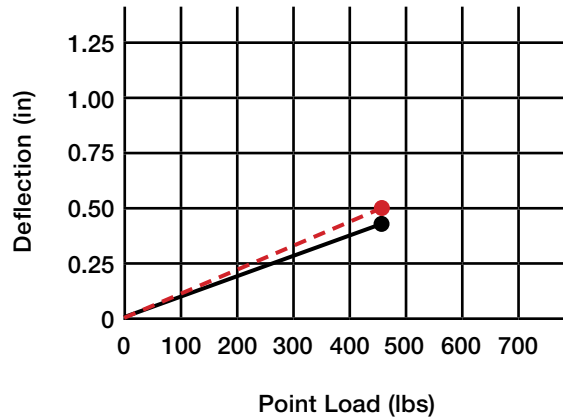
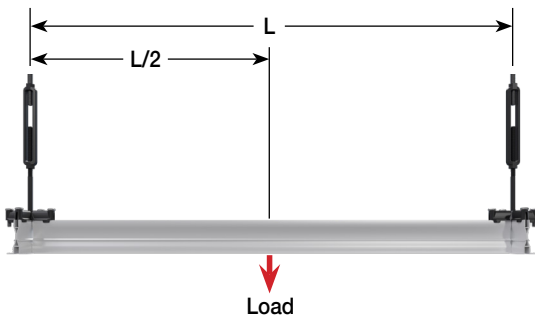

Calculate midspan beam deflection at any point below yield

$$S = \frac{WL^3}{48EI}$$

S = deflection
 W = load
 L = as noted
 E = 10x10⁶ lbs/in²
 I = .153 in⁴

————— 4x4 hanger spacing
 - - - - - 4x6 hanger spacing

On Center Hanger Spacing Module	Max Uniform Load	Max. Safe Working Load (Point Load) per module area	Mid Span Deflection @ Max. Safe Working Load	Safety Factor
4' x 4'	75 lbs / ft ²	475 lbs	0.44"	2x
4' x 6'	50 lbs / ft ²	445 lbs	0.48"	2x

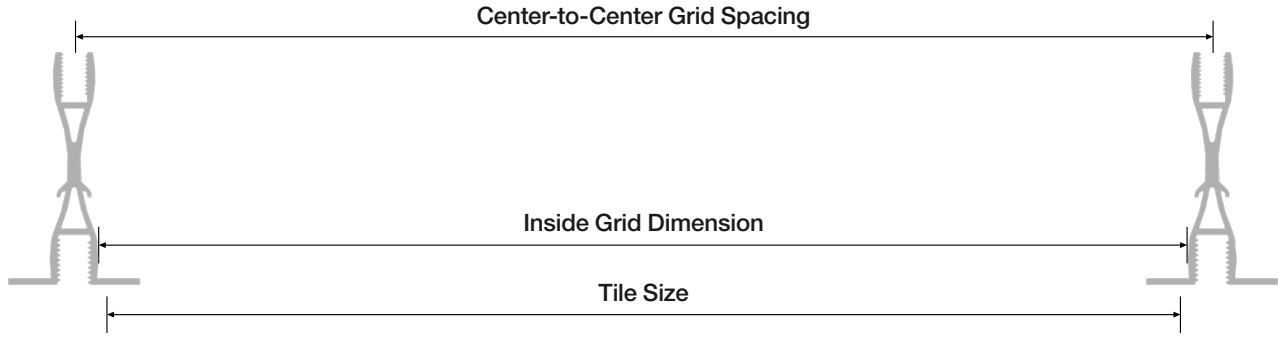

If you want the grid spacing to be on a 24" x 24" or 24" x 48" module size, use this table to determine tile size requirement:

Grid Profile	Grid Spacing (L x W)	Trim Size (L x W)	Hanger Spacing
3/8"-16 Bottom Slot	24" x 24"	23 7/32" x 23 7/32" +/- 1/8"	48" x 48"
	24" x 48"	23 7/32" x 47 7/32" +/- 1/8" (see example below)	48" x 48"

Note: Maximum Tile Size = Inside Grid Dimension minus 1/8". Minimum Tile Size is based on a minimum overlap on the extrusion flange of 1/8" when the tile is shifted all the way to one side.

If you want the grid spacing to be on a larger module size to fit standard 24" x 24" or 24" x 48" nominal tile sizes, use this table:

Grid Profile	Grid Spacing (L x W)	Trim Size (L x W)	Hanger Spacing
3/8"-16 Bottom Slot	24 1/2" x 48 1/2"	23 3/4" x 47 3/4" +/- 1/8" (see example below)	49" x 48 1/2"

Note: Maximum Tile Size = Inside Grid Dimension minus 1/8". Minimum Tile Size is based on a minimum overlap on the extrusion flange of 1/8" when the tile is shifted all the way to one side.

Sizing Based on 24" x 48" Grid Spacing

Sizing Based on 24" x 48" Nominal Tile Size

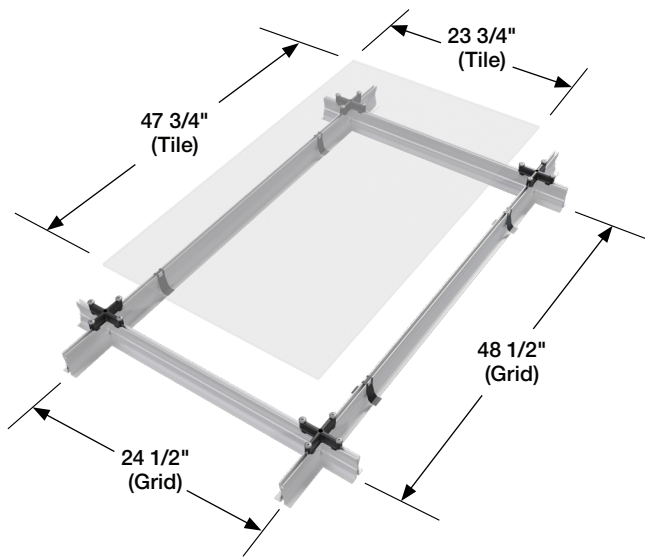
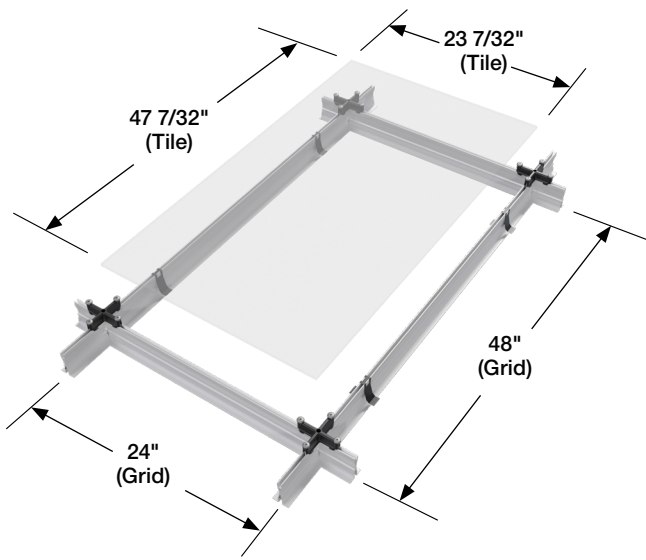

Field Connector Assembly - Connection of Mains to Structural Tees

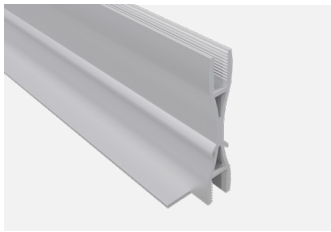

Structural tee coped for simplified installation and stronger connections

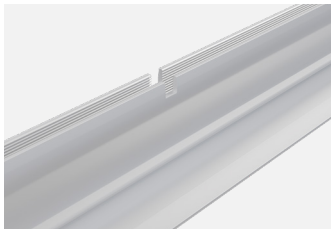

Main runners notched to positively position connectors on center every time

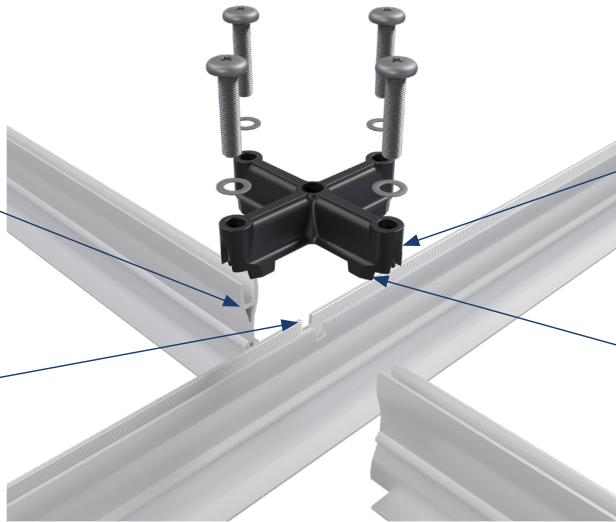

Field connector PN47690



Ribs on connector to align with grid and prevent racking

XL Connector Assembly - Main Beam to Main Beam Connection

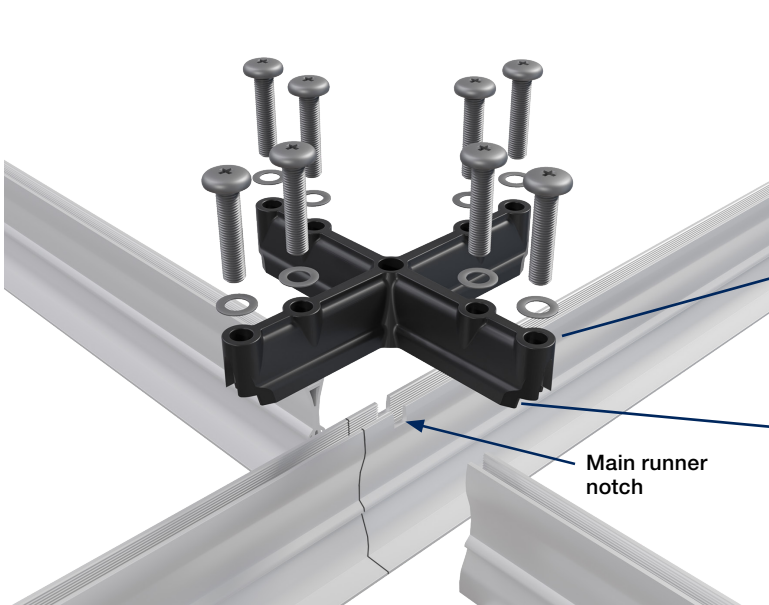

Main runner notch



XL connector - 8 Hole PN47691

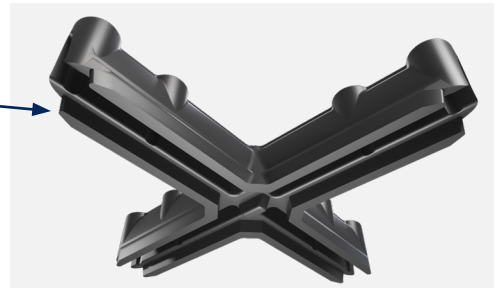

XL connector is designed for additional support at the ends of each main runner.

Perimeter Connector, Straight Connector, Corner Connector

Perimeter connector can be cut to be used in various locations to connect grid together.



Corner connector PN47279



Straight connector PN47629



Perimeter connector PN47728

Main Runners and Structural Tees

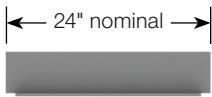

24" and 48" structural tees have coped ends which allow the grid to rest on the longer sections for stronger connections.

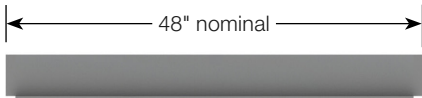

48" structural tee may have a notch depending on the ceiling layout.

12' main runners are notched every 24" on center for proper alignment and spacing of the connectors.

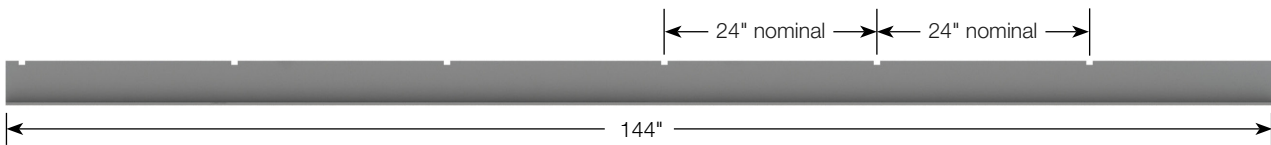

Note: Structural tee and main runner dimensions are nominal and are adjusted for custom-sized ceiling grid designs

Tate Grid+ LEC End Insert

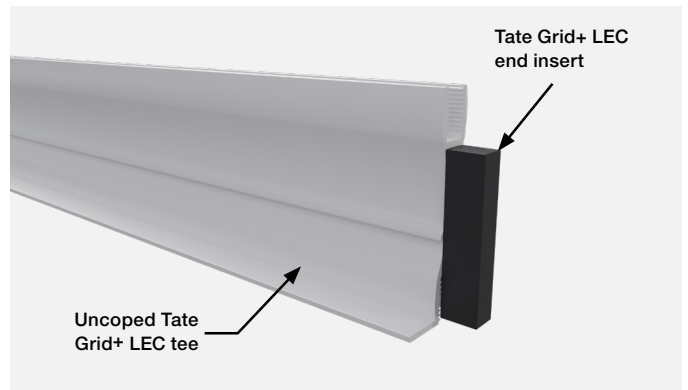
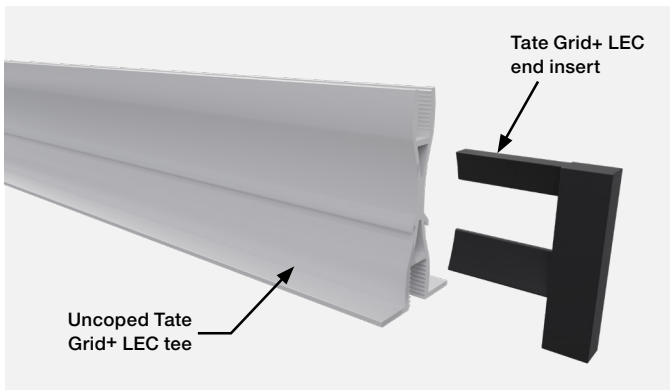

End insert PN48598

Perimeter Details

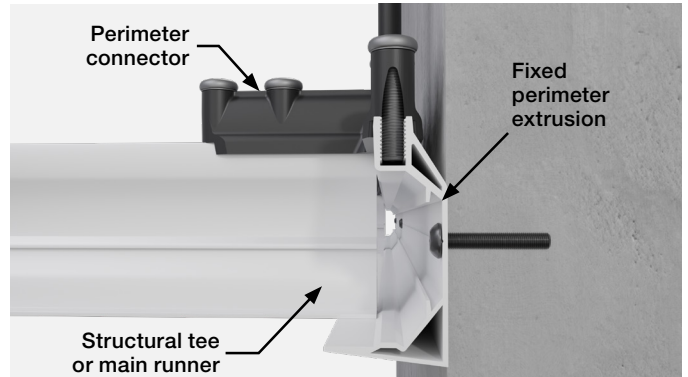
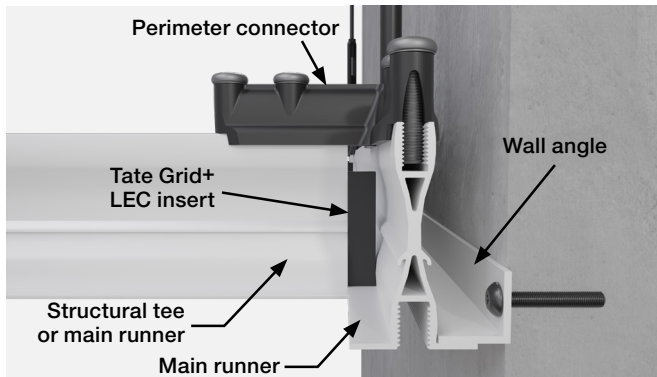

Floating Installation Detail

Main runners are utilized when installing with a floating perimeter detail. When installing with a floating perimeter, perimeter connectors are utilized to connect a structural tee or a main runner to a floating perimeter main.

Additionally it is recommended to utilize a wall angle attached to the perimeter to close up the ceiling and prevent air leakage.

The Tate Grid+ LEC end insert is used for additional support at the cut end of the uncoped perimeter grid.

Fixed Installation Detail

Fixed perimeter extrusions are designed to create a fixed perimeter detail. Fixed perimeter extrusions can be cut on site to desired length when assembled along perimeter walls. Fixed perimeter extrusions are bolted directly to the wall with appropriate fasteners for wall type.

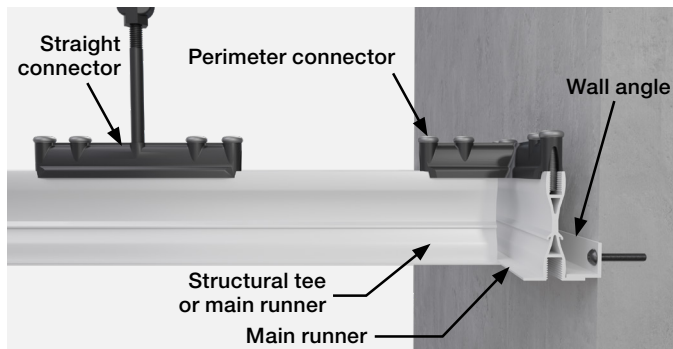

Individually Supported Grid Members with Floating Perimeter Installation Detail

Main runners are utilized when installing with a floating perimeter detail. When installing with a floating perimeter, perimeter connectors are utilized to connect a structural tee or a main runner to a floating perimeter main. A straight connector with a rod drop is required within 12" from the perimeter on every structural tee or main runner that is connected to a floating perimeter main.

Additionally, it is recommended to utilize a wall angle attached to the perimeter to close up the ceiling and prevent air leakage.

Turnbuckle Assembly

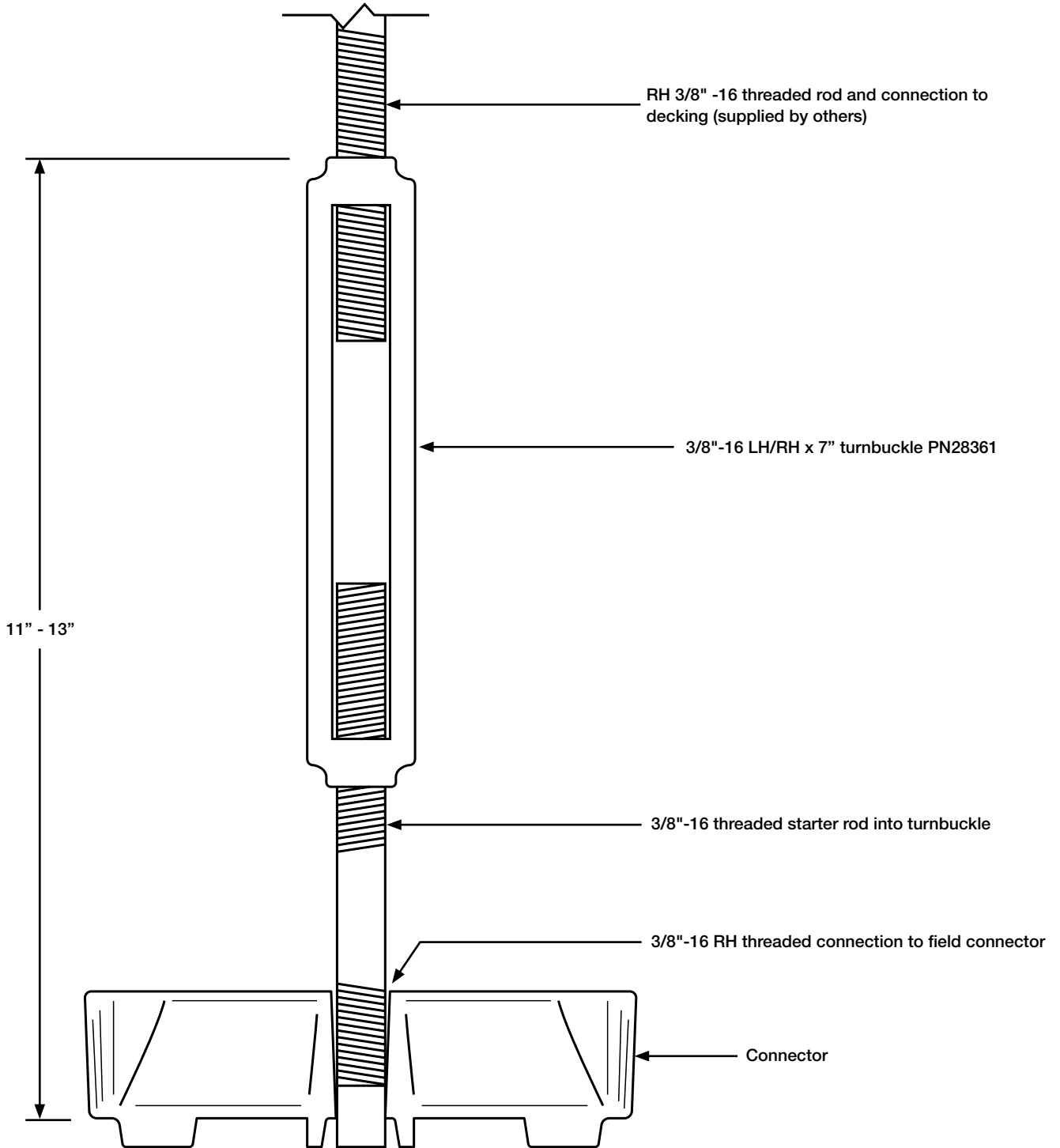

Safety Guidelines**THIS INFORMATION MUST BE SHARED WITH ALL SERVICE PROVIDERS WHO INTEND TO SUSPEND SERVICES FROM THE TATE GRID+ LEC SYSTEM**

Tate Grid+ LEC is a structural ceiling system designed to support static vertical loads. When installing services to the bottom 3/8"-16 threaded channel, the following instructions must be adhered to:

1. Refer to table for maximum loads for given hanger spacing.
 - a. Exceeding these values may cause a failure in the system.
2. Torque the threaded rod or bolts between 20 in-lbs and 30 in-lbs. Over torquing will damage the threads of the 3/8"-16 slot reducing the load capacity of the Tate Grid+ LEC System.
 - a. Failure to adhere to this may result in the shearing of bottom slot threads reducing the load capacity of the Tate Grid+ LEC system.
3. Equal care must be taken during the installation of the Tate Grid+ LEC to install the top screws connecting the Tate Grid+ LEC to the suitable connector at a torque limit between 20 in-lbs and 30 in-lbs.
 - a. Failure to adhere to this may result in the shearing of top slot threads reducing the load capacity of the Tate Grid+ LEC system.
4. Only screws supplied by Tate should be used on the top slot.
 - a. Failure to adhere to this may result in the reduction of the load capacity of the Tate Grid+ LEC system.
5. There must be at least 1/2" thread engagement between threaded rod or bolt supporting the suspended service(s).
 - a. Failure to adhere to this may result in the reduction of the load capacity of the Tate Grid+ LEC system.
6. Do not impose a dynamic load on the connection to Tate Grid+ LEC. During installation of supported services, bracing is required to prevent dynamic load on the Tate Grid+ LEC ceiling.
 - a. Moment forces imposed on the Tate Grid+ LEC system may cause failure of the connection between the services and the Tate Grid+ LEC system.
7. All bottom thread fixings should be completed with suitable washers.
8. Tate Grid+ LEC is NOT a walk-on ceiling.
9. In certain conditions the loading capacity of the Tate Structural Ceiling System may be greater than the loading capacity of the building structure and/or means of attachment to the building structure. Consult with a licensed structural engineer to obtain site specific recommendations regarding the attachment of the Tate Structural Ceiling System and any associated loading to the building structure.
10. Structural ceiling systems as a whole shall be analyzed and designed to local codes by a qualified engineer.



7001 Columbia Gateway Drive, Suite 500
Columbia, MD 21046
T: 410.799.4200 E: info.amer@tateglobal.com
tateglobal.com

Tate reserves the right to amend product information without prior notice. Care has been taken to ensure that the contents of this publication are accurate, but Tate, its parent company and its subsidiary companies do not accept responsibility for errors or information that is found to be misleading or outdated. Suggestions for, or descriptions of, technical specifications and the end user or application of products are provided and must be verified prior to use. **To ensure you are viewing the most recent and accurate product information, please scan the QR code.**

